

Intro

The JGA2069 is a universal control unit with two analog inputs and four analog outputs:

- 1x current input (0 ... 20 mA or 4 ... 20 mA)
- 1x voltage input (0 ... 5V or 0 ... 10 V)
- 4x current output (4 ... 20 mA)



Liability and warranty

Every JGA2069 is checked before sending for correct operation.

Therefore Boutronic has a warranty period of 1 year.

The warranty expires if:

- The defect is caused by gross negligence or by improper installation
- Repairs and/or modifications to the JGA2069 without permission from Boutronic.

Boutronic is in no way liable for damage caused as a direct or indirect consequence by the use of the JGA2069.

Manual JGA2069 Current Splitter
December 2023
From software version 1.0a

Boutronic B.V.
Edisonstraat 24
2691GT 's-Gravanzande
www.boutronic.nl

Index

Intro	1
Liability and warranty	1
Index	2
Connections.....	3
Power supply input	3
Power supply output	4
Connection example	4
Internal or external power supply	4
Global overview.....	5
Current input	5
Voltage output.....	5
Calibration of input/output levels.....	6
Current outputs	6
Output delay	6
Potentiometer	6
Software	7
Programming button	7
DIP-switches.....	7
DIP-switches 1 till 4: Source selection current outputs	7
DIP-switch 5: no function	7
DIP-switch 6: Deceleratie	7
DIP-switch 7: Current input range.....	7
DIP-switch 8: Voltage input range.....	7
Changing settings using the BoutronicStudio	8
Technical specifications.....	9
General	9
Power	9
Inputs & outputs	9
Current input.....	9
Voltage input.....	9
Drivetimes	9
Current output	9
Additional filtering.....	10
Measurements.....	10
Software versions	11
Software check	11
v1.0a.....	11
Settings	12

Connections

In the figure below, the JGA2069 is shown schematically:

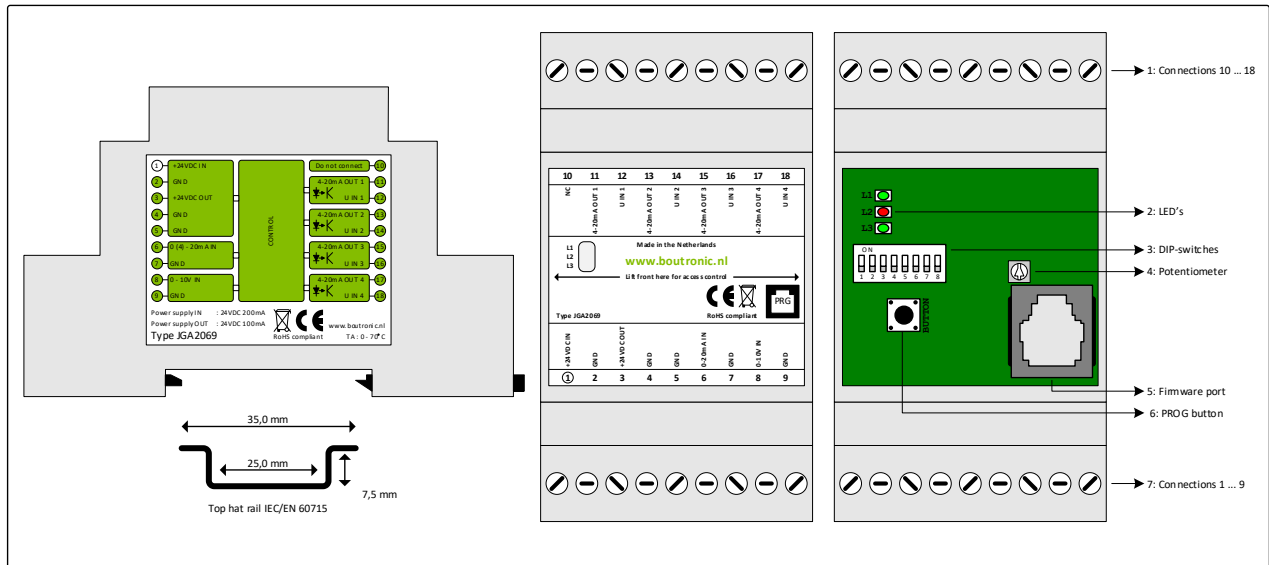

Figure 1: schematic overview JGA2069

Nr	Unit	Description
1	Connection 10 ... 18	Connection for the four current outputs
2	LED's	L1: Power L2: When this LED is on, the analog outputs are increasing or decreasing. L3: This LED is on when the button is pressed During startup all LED's will turn on and off in the following order: L1, L2 and finally L3
3	DIP-switches	Switches to turn options on or off (see chapter: DIP-switches)
4	Potentiometer	With this potentiometer you can set the total drive time for the outputs going from minimum to maximum output level (0 ... 20 sec) ¹
5	Firmware port	Connection to PCB (with a Boutronic dongle) for firmware update or programming settings
6	Programming button	No function.
7	Connection 1 ... 9	Connection 1 ... 9, see front for type of connections

1. Software drive time must be set at 0 seconds.

Power supply input

The JGA2069 is supplied with a DC power supply that is internally single-sided rectified and feeds the internal controller and the voltage output.

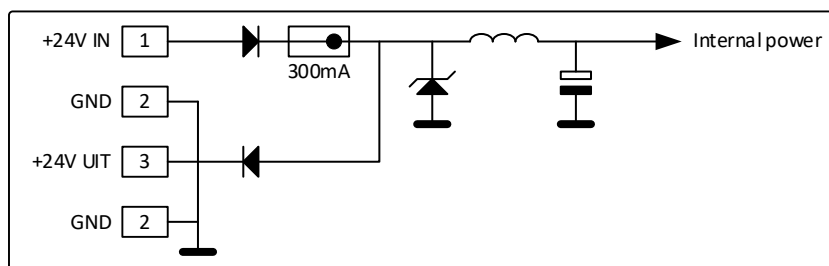

Figure 2: Simple schematic of the power supply

Power supply output

The power out is the same as the power input (single-sided rectified and with capacitor buffered) and has an internal resettable fuse. This power supply can be used to power the 4... 20 mA outputs.

Connection example

Internal or external power supply

Below is the connection diagram in which the internal power supply is used to power output 4. Due to this method, there is no optical separation between the JGA2069 and the external systems to which current output 4 is connected.

Current outputs 1 till 3 do have optical separation, because these outputs are supplied using an external power supply.

The outputs can be controlled using the current input or the voltage input. Which input controls the output is determined by the state of the DIP-switches, see figure 4 or chapter DIP-switches for more information.

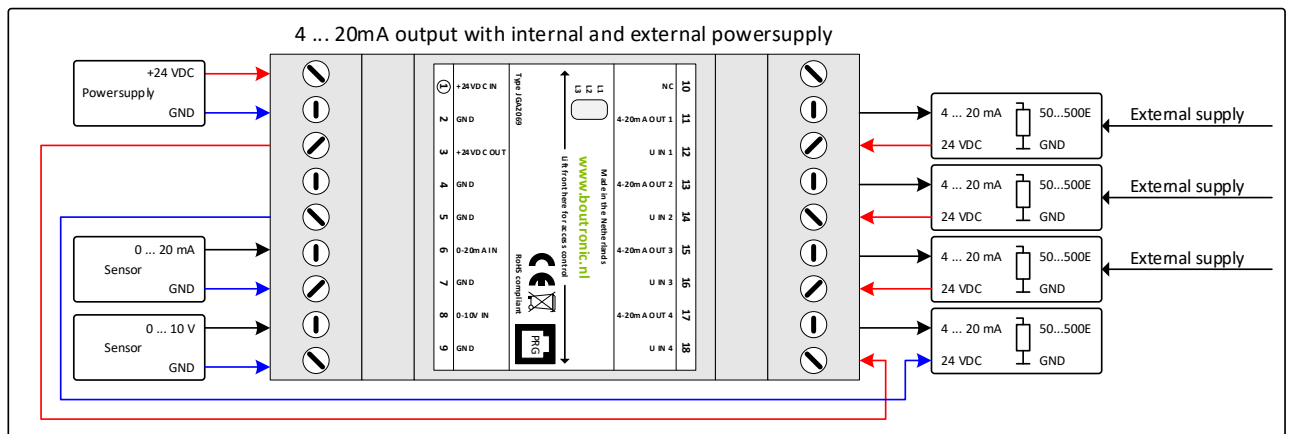

Figure 3: Connection example

Global overview

In the figure below the connection diagram can be seen with an explanation overview.

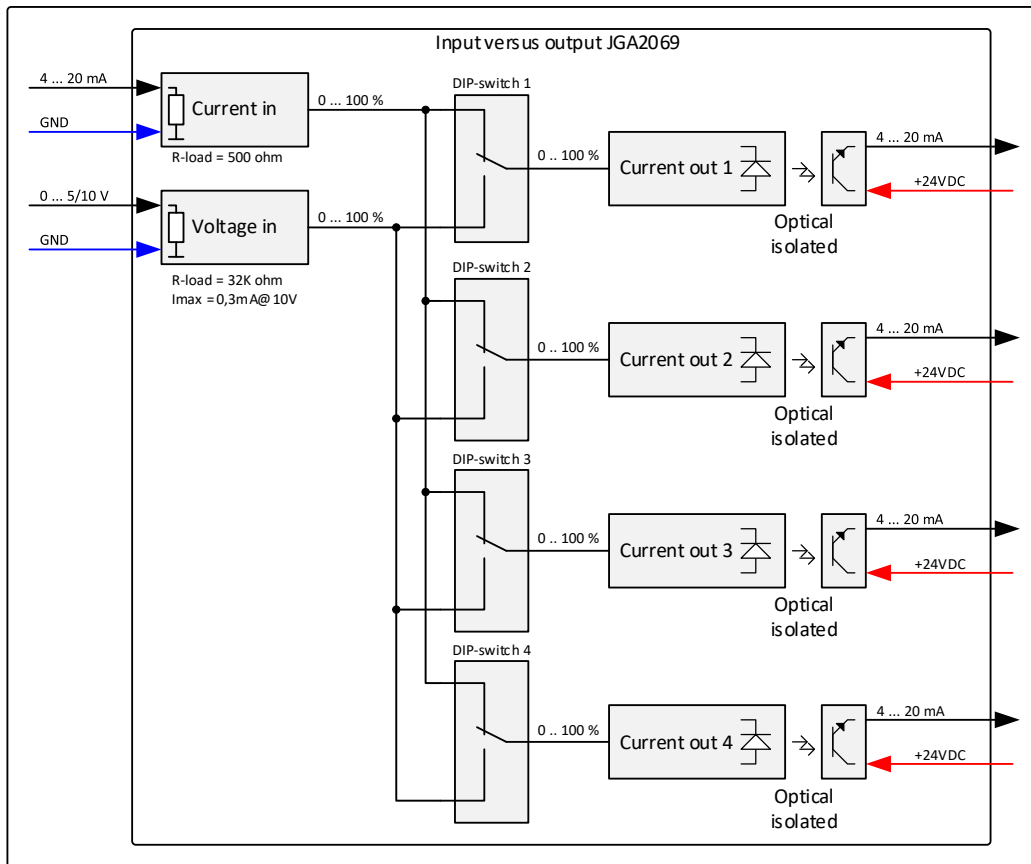

Figure 4: Schematic of global overview

Current input

A signal of 4 ... 20 mA is applied to the current input. This signal is read and converted to a 0 ... 100% value. If the current input is less than or equal to 4 mA, the JGA2069 will limit the value to 0%, if the current input is greater or equal than 20 mA, the JGA2069 will limit the value to 100%.



Note: the maximum current that may be applied to the current input is 30 mA.

The range can be selected through a DIP-switch. For more information see chapter DIP-switches.

Voltage output

A signal of 0 ... 5V or 0 ... 10 V is applied to the voltage input. This signal is read and converted to a 0 ... 100% value. When the voltage input is lower the JGA2069 will limit the value to 0%, if the voltage input is higher the value will be limited to 100%.



Note: the maximum voltage that may be applied to the voltage input is 30 V.

The range can be selected through a DIP-switch. For more information see chapter DIP-switches.

Calibration of input/output levels

The inputs will be pre-calibrated at 4 ... 20 mA and 0 ... 10V. The outputs will be pre-calibrated at 4 ... 20mA. If desired the input/output levels can be recalibrated using the BoutronicStudio software.

Current outputs

The JGA2069 has four optically isolated current outputs. This provides a simple way to make a connection between different power supplies. The current outputs will adjust according to the measured input signal. The state of the DIP-switches decide which input is being followed (see chapter DIP-switches).

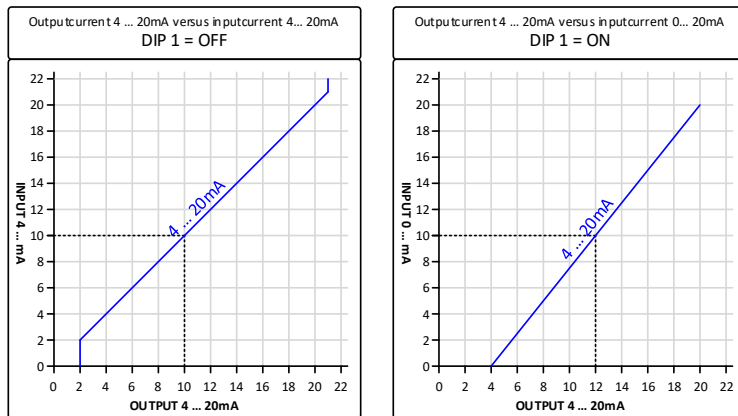

Figure 5: schematic overview of Input current vs output current

Output delay

The delay with which the current outputs and voltage output run to the desired value can be determined using two ways:

- The potentiometer 0 ... 20 seconds
- Software 0 ... 6000 seconds

Potentiometer

When the potentiometer is turned completely to the left, the drive time will be 0 seconds, when it's turned completely to the right, the drive time will be 20 seconds. Typically, the potentiometer will be in the middle and have a drive time of 10 seconds.



Note: The software setting has to be set at 0 seconds (also the factory setting), in order to let the potentiometer determine the drive time. See chapter 'Changing settings with the BoutronicStudio' to find out how the settings for the JGA2069 can be changed using the BoutronicStudio.

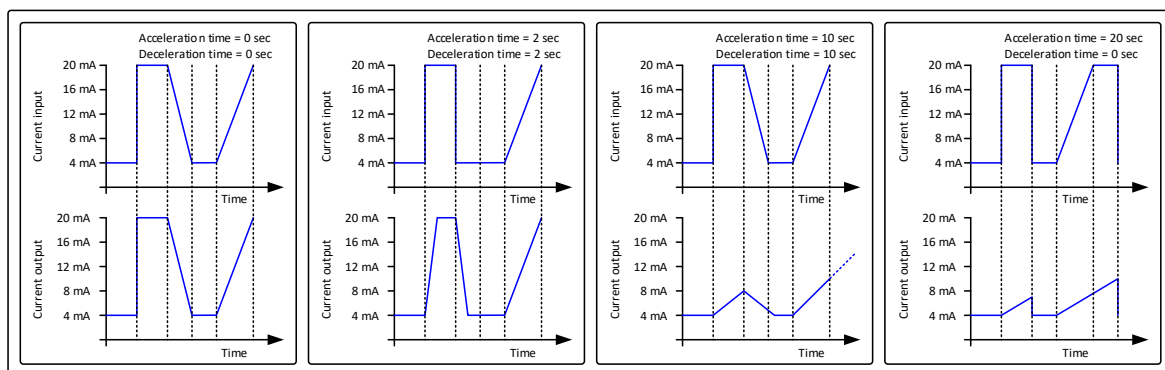

Figure 6: Schematic overview of drive time delay

Software

The drive time can be change for each individual output and can be set from 0 ... 6000 seconds. When a value higher than 0 is entered, that value will be used. The position of the potentiometer will be ignored for that specific output.

Programming button

The programming button does not have a function.

DIP-switches

There are 8 DIP-switches on the JGA2069 which can be used to change the settings.

DIP-switch	OFF	ON
1	Current output 1 follows the current input	Current output 1 follows the voltage input
2	Current output 2 follows the current input	Current output 2 follows the voltage input
3	Current output 3 follows the current input	Current output 3 follows the voltage input
4	Current output 4 follows the current input	Current output 4 follows the voltage input
5	No function	No function
6	Acceleration and Deceleration according to potentiometer of software settings	Acceleration according to potentiometer of software settings. Deceleration is always 1 second when using potentiometer or is the software set value.
7	Current input is 4 ... 20 mA	Current input is 0 ... 20 mA
8	Voltage input is 0 ... 10 V	Voltage input is 0 ... 5 V

DIP-switches 1 till 4: Source selection current outputs

With DIP-switch 1 till 4 the source for the current output is selected:

- When the switch is OFF, that current output will use the current input as a source.
- When the switch is ON, that current output will use the voltage output as a source.

DIP-switch 5: no function

This switch does not hold a function.

DIP-switch 6: Deceleratie

DIP-switch 6 can be used to change the deceleration time of the outputs from the potentiometer to the software settings. Typically, the software settings will be at 0 seconds, this means the deceleration time will also be at 0 seconds. At 0 seconds the output will lower very quickly. The acceleration will still use the value of the potentiometer

This option only functions when the deceleration settings are set at 0 seconds (use potentiometer). In case that the software value has been entered, then the deceleration will use this value.

DIP-switch 7: Current input range

With DIP-switch 7 the range of the current input can be selected:

- When the switch is OFF, the current input measures from 4 ... 20 mA.
- When the switch is ON, the current input measures from 0 ... 20 mA.

DIP-switch 8: Voltage input range

With DIP-switch 8 the range of the voltage input can be selected:

- When the switch is OFF, the voltage input will measure from 0 ... 10 V.
- When the switch is ON, the voltage input will measure from 0 ... 5 V.

Changing settings using the BoutronicStudio

The JGA2069 can be connected to the BoutronicStudio (Boutronic Studio 3 v3.0f R3 or higher)
The JGA2069 will be connected via the firmware port to the computer through a Boutronic USB dongle. After that the JGA2069 can be configured using the BoutronicStudio



Note: In order alter the setting on the JGA2069, a software version BoutronicStudio 3 v3.0f R3 or higher is needed.

Look at the user manual of Boutronic Studio to find out how a device has to be connected.

Technical specifications

General

Description	Value	Unit	Remarks
Measurement	90 x 36 x 57	mm	L x B x H
Mounting	DIN-rail (Top hat rail)		IEC/EN 60715
Material	Plastic ABS		
Weight	75	gram	
Temperature storage	-20 ... +60	°C	
Temperature operational	0 ... +70	°C	
Relative humidity	10 ~ 95%	%	At 40°C, non-condensing
Protecting range	IP20		

Power

Description	Min	Typ.	Max	Unit	Remarks
Power in	20	24	30	VDC	
	-	35	200	mA	
Power out	19	-	29	VDC	This voltage is equal to the power supply minus 1 V.
	-	-	100	mA	With a resettable fuse.

Inputs & outputs

Current input

Description	Min	Typ.	Max	Unit	Remarks
Input voltage	-	-	30	VDC	
Input current	0	4 ... 20	30	mA	
Input impedance		500		Ω	

Voltage input

Description	Min	Typ.	Max	Unit	Remarks
Input voltage	0	10	30	VDC	
Input current	0	0,3	1	mA	
Internal resistance	-	32000	-	Ω	

Drivetimes

Description	Min	Typ.	Max	Unit	Remarks
Drive time with potentiometer	0	10	20	sec	
Drive time with BoutronicStudio	0	0	6000	sec	0 = use potentiometer value

Current output

Description	Min	Typ.	Max	Unit	Remarks
Separation	-	-	2500	V rms	Optical
Output current	0	20	25	mA	DIP 7 OFF = 4 ... 20 mA
Input voltage	20	24	30	VDC	
Resolution		0,04		mA/step	10 bits
Impedance	50	-	500	Ω	

Additional filtering

If additional filtering is required, an extra capacitor (ELKO) of +/- 4UF7/50V can be placed between the input signal and the GND (minus) of the PLC or the I/O module.

This connection is shown schematically below.

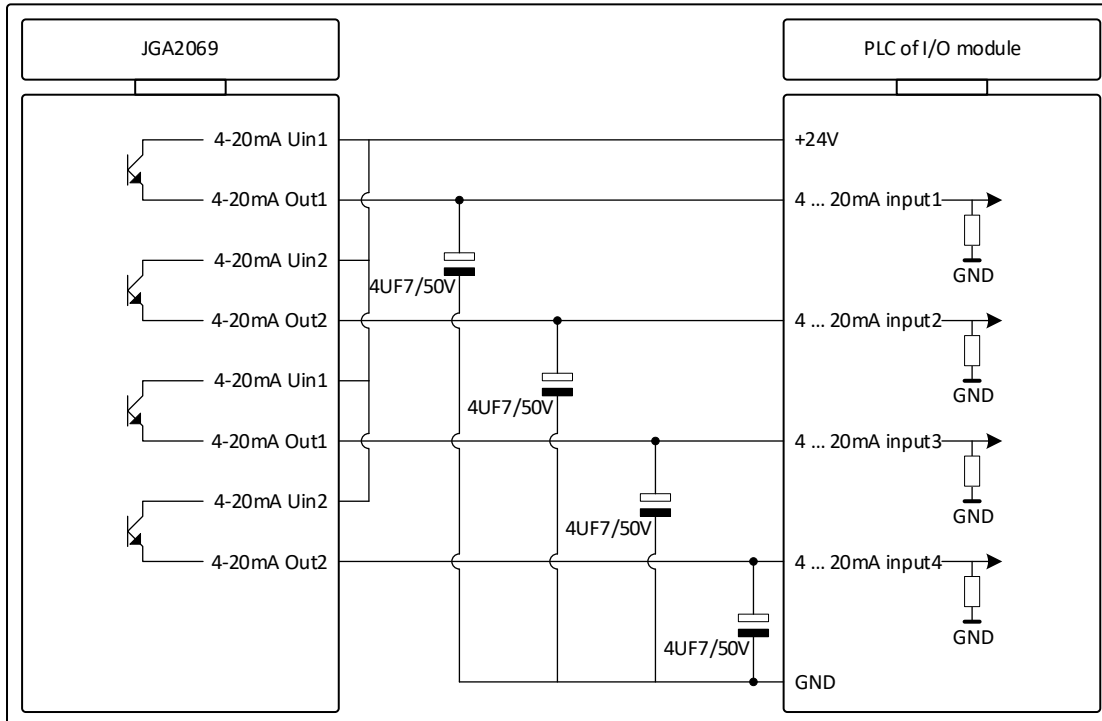

Measurements

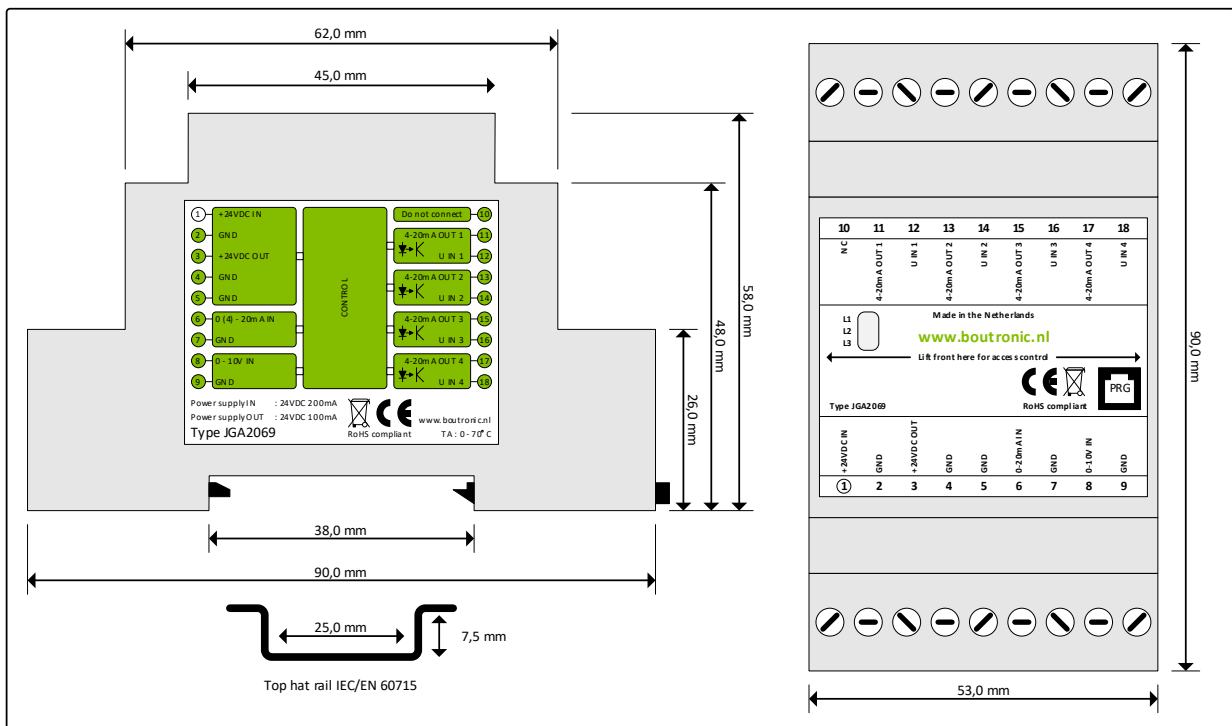

Figure 7: measurements

Software versions

The following software versions are there for the CurrentSplitter 4V JGA2069

Version	Date	Changes
v1.0a	21-12-2023	First version

Product shipped after the release date contain the according software version.

Software check

The software version can be checked by looking at the LED's during the startup of the device.

v1.0a

When power is connected to the JGA2069, all three LED's will be turned on.

Afterwards the LED's will turn off one by one in order: L1 off, then L2 off and finally L3 off.

Settings

The following settings can be altered in the JGA2069.

Setting	Description	Min.	Max.	Typ.
Drive time increasing output x ¹	Time for the current output to go from minimal to maximal when the value is increasing	0 sec. (value of potentiometer is used)	6000 sec.	0 sec. (value of potentiometer is used)
Drive time decreasing output x ¹	Time for the current output to go from minimal to maximal when the value is decreasing	0 sec. (value of potentiometer is used)	6000 sec.	0 sec. (value of potentiometer is used)
Calibration current input 4 mA ²	The value measured by the JGA2069 when 4 mA is presented	0	4095	(varies)
Calibration current input 20 mA ²	The value measured by the JGA2069 when 20 mA is presented	0	4095	(varies)
Calibration voltage input 0V ²	The value measured by the JGA2069 when 0 V is presented	0	4095	(varies)
Calibration voltage input 10V ²	The value measured by the JGA2069 when 10 V is presented	0	4095	(varies)
Calibration current output x ¹ 4 mA ²	Calibration value send by the JGA2069 when 4 mA is sent to the output	0	4095	(varies)
Calibration current output x ¹ 20 mA ²	Calibration value send by the JGA2069 when 20 mA is sent to the output	0	4095	(varies)

1. For all 4 of the current outputs
2. This setting is calibrated in the factory.

When the factory setting is set, the calibration settings from the factory will be reloaded.